

Series ONS

SET-2

कोड नं.
Code No. **55/2/E**

रोल नं.
Roll No.

परीक्षार्थी कोड को उत्तर-पुस्तिका के मुख-पृष्ठ पर अवश्य लिखें।

Candidates must write the Code on the title page of the answer-book.

- कृपया जाँच कर लें कि इस प्रश्न-पत्र में मुद्रित पृष्ठ 16 हैं।
- प्रश्न-पत्र में दाहिने हाथ की ओर दिए गए कोड नम्बर को छात्र उत्तर-पुस्तिका के मुख-पृष्ठ पर लिखें।
- कृपया जाँच कर लें कि इस प्रश्न-पत्र में 26 प्रश्न हैं।
- कृपया प्रश्न का उत्तर लिखना शुरू करने से पहले, प्रश्न का क्रमांक अवश्य लिखें।
- इस प्रश्न-पत्र को पढ़ने के लिए 15 मिनट का समय दिया गया है। प्रश्न-पत्र का वितरण पूर्वाह्न में 10.15 बजे किया जाएगा। 10.15 बजे से 10.30 बजे तक छात्र केवल प्रश्न-पत्र को पढ़ेंगे और इस अवधि के दौरान वे उत्तर-पुस्तिका पर कोई उत्तर नहीं लिखेंगे।
- Please check that this question paper contains 16 printed pages.
- Code number given on the right hand side of the question paper should be written on the title page of the answer-book by the candidate.
- Please check that this question paper contains 26 questions.
- **Please write down the Serial Number of the question before attempting it.**
- 15 minute time has been allotted to read this question paper. The question paper will be distributed at 10.15 a.m. From 10.15 a.m. to 10.30 a.m., the students will read the question paper only and will not write any answer on the answer-book during this period.

भौतिक विज्ञान (सैद्धान्तिक)

PHYSICS (Theory)

निर्धारित समय : 3 घण्टे

Time allowed : 3 hours

अधिकतम अंक : 70

Maximum Marks : 70

55/2/E

1

P.T.O.



सामान्य निर्देश :

- (i) सभी प्रश्न अनिवार्य हैं। इस प्रश्न-पत्र में कुल 26 प्रश्न हैं।
- (ii) इस प्रश्न-पत्र के 5 भाग हैं : खण्ड अ, खण्ड ब, खण्ड स, खण्ड द और खण्ड य।
- (iii) खण्ड अ में 5 प्रश्न हैं, प्रत्येक का 1 अंक है। खण्ड ब में 5 प्रश्न हैं, प्रत्येक के 2 अंक हैं। खण्ड स में 12 प्रश्न हैं, प्रत्येक के 3 अंक हैं। खण्ड द में 4 अंक का एक मूल्याधारित प्रश्न है और खण्ड य में 3 प्रश्न हैं, प्रत्येक के 5 अंक हैं।
- (iv) प्रश्न-पत्र में समग्र पर कोई विकल्प नहीं है। तथापि, दो अंकों वाले एक प्रश्न में, तीन अंकों वाले एक प्रश्न में और पाँच अंकों वाले तीनों प्रश्नों में आन्तरिक चयन प्रदान किया गया है। ऐसे प्रश्नों में आपको दिए गए चयन में से केवल एक प्रश्न ही करना है।
- (v) जहाँ आवश्यक हो आप निम्नलिखित भौतिक नियतांकों के मानों का उपयोग कर सकते हैं :

$$c = 3 \times 10^8 \text{ m/s}$$

$$h = 6.63 \times 10^{-34} \text{ Js}$$

$$e = 1.6 \times 10^{-19} \text{ C}$$

$$\mu_0 = 4\pi \times 10^{-7} \text{ T m A}^{-1}$$

$$\epsilon_0 = 8.854 \times 10^{-12} \text{ C}^2 \text{ N}^{-1} \text{ m}^{-2}$$

$$\frac{1}{4\pi\epsilon_0} = 9 \times 10^9 \text{ N m}^2 \text{ C}^{-2}$$

$$\text{इलेक्ट्रॉन का द्रव्यमान} = 9.1 \times 10^{-31} \text{ kg}$$

$$\text{न्यूट्रॉन का द्रव्यमान} = 1.675 \times 10^{-27} \text{ kg}$$

$$\text{प्रोटॉन का द्रव्यमान} = 1.673 \times 10^{-27} \text{ kg}$$

$$\text{आवोगाद्रो संख्या} = 6.023 \times 10^{23} \text{ प्रति ग्राम मोल}$$

$$\text{बोल्ट्जमान नियतांक} = 1.38 \times 10^{-23} \text{ JK}^{-1}$$

General Instructions :

- (i) *All questions are compulsory. There are 26 questions in all.*
- (ii) *This question paper has five sections : Section A, Section B, Section C, Section D and Section E.*
- (iii) *Section A contains five questions of one mark each, Section B contains five questions of two marks each, Section C contains twelve questions of three marks each, Section D contains one value based question of four marks and Section E contains three questions of five marks each.*
- (iv) *There is no overall choice. However, an internal choice has been provided in one question of two marks, one question of three marks and all the three questions of five marks weightage. You have to attempt only one of the choices in such questions.*
- (v) *You may use the following values of physical constants wherever necessary.*

$$c = 3 \times 10^8 \text{ m/s}$$

$$h = 6.63 \times 10^{-34} \text{ Js}$$

$$e = 1.6 \times 10^{-19} \text{ C}$$

$$\mu_0 = 4\pi \times 10^{-7} \text{ T m A}^{-1}$$

$$\epsilon_0 = 8.854 \times 10^{-12} \text{ C}^2 \text{ N}^{-1} \text{ m}^{-2}$$

$$\frac{1}{4\pi\epsilon_0} = 9 \times 10^9 \text{ N m}^2 \text{ C}^{-2}$$

$$\text{Mass of electron} = 9.1 \times 10^{-31} \text{ kg}$$

$$\text{Mass of neutron} = 1.675 \times 10^{-27} \text{ kg}$$

$$\text{Mass of proton} = 1.673 \times 10^{-27} \text{ kg}$$

$$\text{Avogadro's number} = 6.023 \times 10^{23} \text{ per gram mole}$$

$$\text{Boltzmann constant} = 1.38 \times 10^{-23} \text{ JK}^{-1}$$

खण्ड - अ

SECTION - A

1. किसी चालक की चालकता को परिभाषित कीजिए। यह किन कारकों पर निर्भर करती है? 1

Define the term conductivity of a conductor. On what factors does it depend ?

2. दो सिग्नलों A और B को किसी NOR गेट के निवेशों के रूप में उपयोग किया गया है। निर्गत तरंगरूप खींचिए। 1

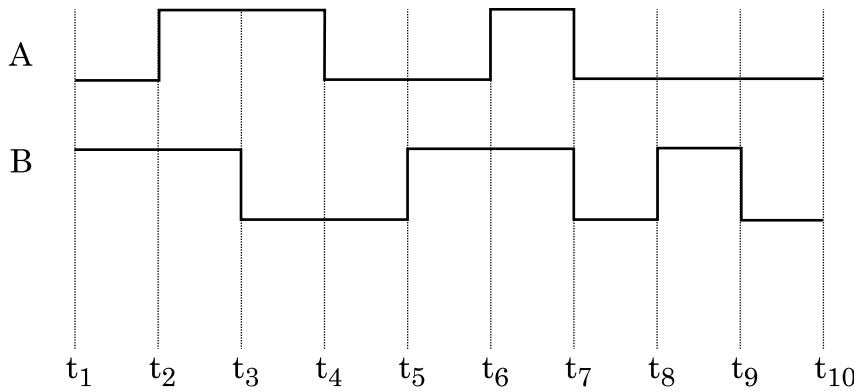

Two signals A and B are used as inputs of a NOR gate. Draw the output wave form.

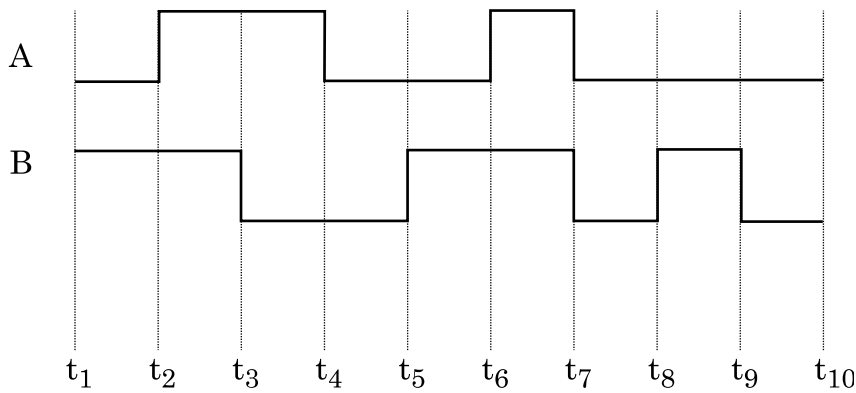

3. कोई a.c. स्रोत जिसकी वोल्टता $V = V_0 \sin \omega t$ है, को किसी आदर्श प्रेरक से संयोजित किया गया है। वोल्टता V और धारा i का ωt के साथ विचरण दर्शाने के लिए ग्राफ खींचिए। 1

An a.c. source of voltage $V = V_0 \sin \omega t$ is connected to an ideal inductor. Draw graphs of voltage V and current i versus ωt .

4. व्याख्या कीजिए कि स्थायी अवस्था में किसी आदर्श संधारित्र को a.c. स्रोत से संयोजित करने पर धारा प्रवाहित होती है, परन्तु d.c. स्रोत से संयोजित करने कोई धारा प्रवाहित नहीं होती। 1

Explain why current flows through an ideal capacitor when it is connected to an a.c. source but not when it is connected to a d.c. source in a steady state.

5. दो पोटैन्शियोमीटरों P और Q के तारों के प्रकरण में लम्बाई l के साथ विभवान्तर के विचरण नीचे दिए अनुसार हैं। दो प्राथमिक सेलों की emf की तुलना करने के लिए इनमें से आप किसे प्राथमिकता देंगे और क्यों? 1

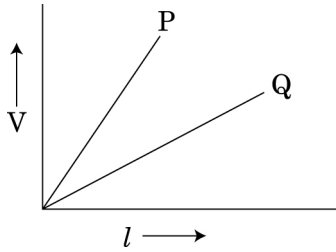

The variation of potential difference V with length l in case of two potentiometer wires P and Q is as shown. Which one of these will you prefer for comparing emfs of two primary cells and why?

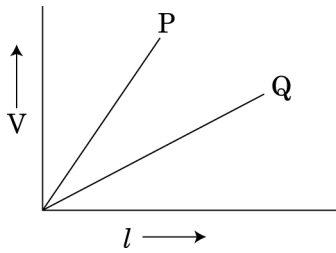

खण्ड - ब
SECTION - B

6. (i) अवरक्त तरंगों किस प्रकार उत्पन्न होती हैं? इनका एक महत्वपूर्ण उपयोग लिखिए। 2
(ii) समतापमण्डल के शीर्ष पर ओजोन की पतली परत मानव की उत्तरजीविता के लिए निर्णायक है। क्यों?
(i) How are infrared waves produced? Write their one important use.
(ii) The thin Ozone layer on top of the stratosphere is crucial for human survival. Why?
7. कोई हाइड्रोजन परमाणु जो अपनी निम्नतम अवस्था में है, किसी फोटॉन का अवशोषण करके 12.5 eV ऊर्जा की उत्तेजित अवस्था में आ जाता है। उत्सर्जित विकिरण की दीर्घतम तरंगदैर्घ्य परिकलित कीजिए और उस श्रेणी को पहचानिए जिससे वह संबंधित है। (रिडबर्ग नियतांक $R = 1.1 \times 10^7 \text{ m}^{-1}$ लीजिए) 2

अथवा

बोर के परमाणु मॉडल का उपयोग करके प्रथम उत्तेजित अवस्था में इलेक्ट्रॉन की चाल परिकलित कीजिए।

A hydrogen atom initially in its ground state absorbs a photon and is in the excited state with energy 12.5 eV. Calculate the longest wavelength of the radiation emitted and identify the series to which it belongs. [Take Rydberg constant $R = 1.1 \times 10^7 \text{ m}^{-1}$]

OR

Use Bohr model of hydrogen atom to calculate the speed of the electron in the first excited state.

8. किसी एकसमान विद्युत क्षेत्र E में किसी द्वि-ध्रुव को कोण θ_0 से θ_1 तक घूर्णन कराने में किए गए कार्य के लिए व्यंजक व्युत्पन्न कीजिए। 2
Derive an expression for the work done in rotating a dipole from the angle θ_0 to θ_1 in a uniform electric field E .
9. गणितीय विधि द्वारा दर्शाइए कि हाइड्रोजन परमाणु में कक्षीय कोणीय संवेग के क्वान्टीकरण के बोर के अभिगृहीत की व्याख्या दे ब्राग्ली परिकल्पना द्वारा किस प्रकार की गयी है? 2
Show mathematically how Bohr's postulate of quantization of orbital angular momentum in hydrogen atom is explained by de-Broglie's hypothesis.
10. मोबाइल टेलीफोनी की संकल्पना का उल्लेख कीजिए तथा इसकी कार्यविधि का वर्णन कीजिए। 2
State the concept of mobile telephony and explain its working.

खण्ड - स
SECTION - C

11. परिपथ आरेख की सहायता से CE विन्यास में npn ट्रांजिस्टर की अन्तरण क्रिया की संक्षेप में व्याख्या कीजिए। निर्गत और निवेश अभिलाक्षणिकों की प्ररूपी आकृतियां खींचिए। 3

Explain briefly, with the help of a circuit diagram, the transistor action of npn transistor in CE configuration. Draw the typical shapes of input and output characteristics.

12. नीचे दिए गए परिपथ में बिन्दु A और B के बीच तुल्य-धारिता परिकलित कीजिए। यदि A और B के बीच 10 V की बैटरी संयोजित कर दी जाए, तो परिपथ द्वारा बैटरी से लिया गया आवेश परिकलित कीजिए। 3

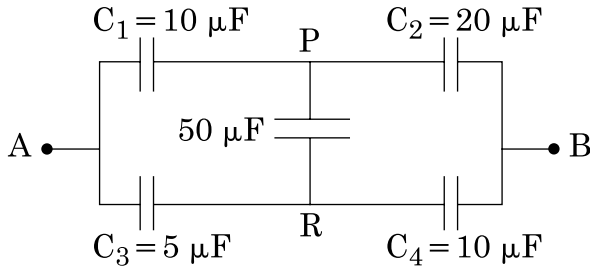

Calculate the equivalent capacitance between points A and B in the circuit below. If a battery of 10 V is connected across A and B, calculate the charge drawn from the battery by the circuit.

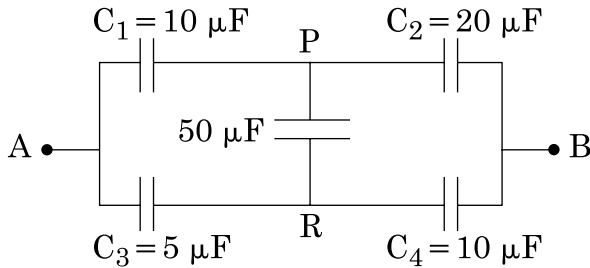

13. किसी गैल्वैनोमीटर को अमीटर तथा वोल्टमीटर में किस प्रकार परिवर्तित किया जाता है? प्रासंगिक आरेख खींचिए तथा प्रत्येक प्रकरण में व्यवस्था का प्रतिरोध ज्ञात कीजिए। गैल्वैनोमीटर का प्रतिरोध G लीजिए। 3

How is a galvanometer converted into a voltmeter and an ammeter? Draw the relevant diagrams and find the resistance of the arrangement in each case. Take resistance of galvanometer as G.

14. (i) पूर्ण आन्तरिक परावर्तन क्या होता है? यह किन आवश्यक शर्तों में घटित होता है? 3
(ii) क्रांतिक कोण और अपवर्तनांक के बीच संबंध ज्ञात कीजिए।
(iii) एक परिघटना लिखिए जिसमें पूर्ण आन्तरिक परावर्तन का उपयोग होता है।
- (i) What is total internal reflection? Under what conditions does it occur?
(ii) Find a relation between critical angle and refractive index.
(iii) Name one phenomenon which is based on total internal reflection.
15. त्रिज्या R के किसी धातु के पतले गोलीय खोल के पृष्ठ पर आवेश Q विद्यमान है। आरेख में 3
दर्शाए अनुसार इस खोल के केन्द्र C पर आवेश $Q/2$ तथा इस खोल से बाहर दूरी x पर स्थित बिन्दु A पर $+2Q$ आवेश स्थित है।
- (i) खोल से गुजरने वाला फ्लक्स ज्ञात कीजिए।
(ii) उपयोग की जाने वाला नियम लिखिए।
(iii) खोल के केन्द्र C तथा बिन्दु A पर स्थित आवेशों पर बल ज्ञात कीजिए।

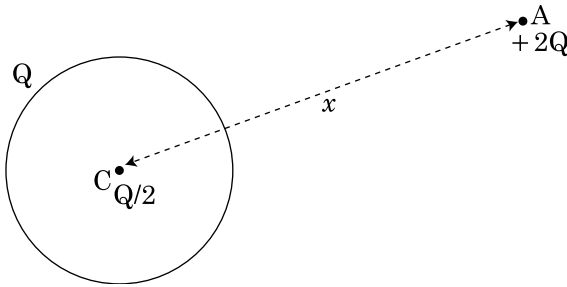

A thin metallic spherical shell of radius R carries a charge Q on its surface. A point charge $Q/2$ is placed at the centre C and another charge $+2Q$ is placed outside the shell at A at a distance x from the centre as shown in the figure.

- (i) Find the electric flux through the shell.
(ii) State the law used.
(iii) Find the force on the charges at the centre C of the shell and at the point A .

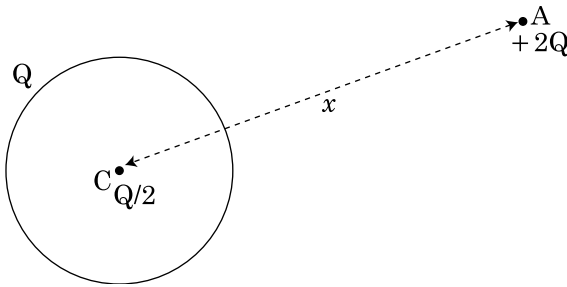

16. (a) परावर्ती दूरदर्शक का व्यवस्था आरेख खींचिए। 3
(b) अपवर्ती दूरदर्शक की तुलना में परावर्ती दूरदर्शक के लाभ लिखिए।

अथवा

- (i) संयुक्त सूक्ष्मदर्शी का व्यवस्था आरेख उस प्रकरण के लिए खींचिए जिसमें अंतिम प्रतिबिम्ब सुस्पष्ट दर्शन की न्यूनतम दूरी पर बनता है।
(ii) संयुक्त सूक्ष्मदर्शी की विभेदन क्षमता के लिए व्यंजक लिखिए। किसी सूक्ष्मदर्शी की विभेदन क्षमता में वृद्धि किस प्रकार की जा सकती है?
(a) Draw a schematic diagram of a reflecting telescope.
(b) State the advantages of reflecting telescope over refracting telescope.

OR

- (i) Draw a schematic ray diagram of a compound microscope when image is formed at distance of distinct vision.
(ii) Write the expression for resolving power of a compound microscope. How can the resolving power of a microscope be increased ?

17. (i) आरेख खींचकर फोटोडायोड की क्रियाविधि का वर्णन कीजिए। 3
(ii) विभिन्न प्रदीप्ति - तीव्रताओं के लिए किसी फोटोडायोड के अभिलाक्षणिक खींचिए।
(iii) यद्यपि पश्च बायसन धारा अग्र बायसन धारा की तुलना में अति दुर्बल होती है, तथापि फोटोडायोड का प्रचालन पश्च बायसन में क्यों किया जाता है?
(i) Describe the working of photodiode by drawing the circuit diagram.
(ii) Draw the characteristics of a photodiode for different illumination intensities.
(iii) Why is photodiode operated in reverse bias even though the reverse bias current is much weaker than the current in forward bias ?

18. α - क्षय के लिए $^{238}\text{U}_{92}$ की अर्धायु 4.5×10^9 वर्ष है। $^{238}\text{U}_{92}$ के 1 g नमूने की सक्रियता परिकलित कीजिए। (दिया है आवोगाद्रो संख्या = 6×10^{26} परमाणु / किलोमोल) 3
Half life of $^{238}\text{U}_{92}$ against α - decay is 4.5×10^9 years. Calculate the activity of 1g sample of $^{238}\text{U}_{92}$? Given Avagadro's number = 6×10^{26} atoms/kmol.



19. (a) यंग के द्विझिरी प्रयोग में दो झिरियों के बीच की दूरी 1 mm तथा पर्दे को झिरियों से 1 m की दूरी पर रखा गया है। 500 nm तरंगदैर्घ्य के प्रकाश के लिए फ्रिंज-चौड़ाई परिकलित कीजिए। 3
- (b) प्रत्येक झिरी की चौड़ाई कितनी होनी चाहिए, कि एकलझिरी पैटर्न के केन्द्रीय उच्चिष्ठ के भीतर द्विझिरी पैटर्न के 10 उच्चिष्ठ प्राप्त हों?
- (a) In Young's double slit experiment, two slits are 1 mm apart and the screen is placed 1 m away from the slits. Calculate the fringe width when light of wavelength 500 nm is used.
- (b) What should be the width of each slit in order to obtain 10 maxima of the double slits pattern within the central maximum of the single slit pattern ?
20. किसी ट्रांसफॉर्मर, जिसमें क्रोड की दो पृथक भुजाओं पर दो कुण्डलियाँ हैं, की प्राथमिक और द्वितीयक कुण्डलियों पर लपेटन के लिए आरेखीय व्यवस्था खींचिए। इसका आधारित सिद्धान्त लिखिए और प्राथमिक और द्वितीयक कुण्डलियों की लपेटनों में फेरों की संख्या के पदों में प्राथमिक और द्वितीयक वोल्टताओं के बीच संबंध ज्ञात कीजिए। किसी आदर्श ट्रांसफॉर्मर के प्रकरण में प्राथमिक और द्वितीयक कुण्डलियों की धाराएँ वोल्टताओं से किस प्रकार संबंधित होती हैं? 3
- Draw a schematic arrangement for winding of primary and secondary coils in a transformer with the two coils on separate limbs of the core. State its underlying principle and find the relation between the primary and secondary voltages in terms of the number of turns of the primary and secondary windings. How are the currents in the primary and secondary coils related to the voltages in the case of an ideal transformer ?
21. GPS (ग्लोबल पोजिशनिंग सिस्टम) क्या होता है? इसकी कार्यविधि का सिद्धान्त लिखिए। What is Global Positioning System ? Explain its working principle in brief. 3
22. दिए गए ग्राफ में, दो भिन्न तीव्रताओं के आपतित विकिरणों तथा दो भिन्न पदार्थों के लिए, अनुप्रयुक्त वोल्टता (V) और प्रकाश विद्युत धारा (I) के विचरण को दर्शाया गया है। आइंस्टीन की प्रकाश विद्युत समीकरण का उपयोग करके वक्रों के ऐसे युगलों को पहचानिए और उनकी व्याख्या कीजिए, जो (i) विभिन्न पदार्थों, परन्तु आपतित विकिरणों की समान तीव्रता, (ii) विभिन्न तीव्रता, परन्तु समान पदार्थ के तदनुरूपी हैं। 3

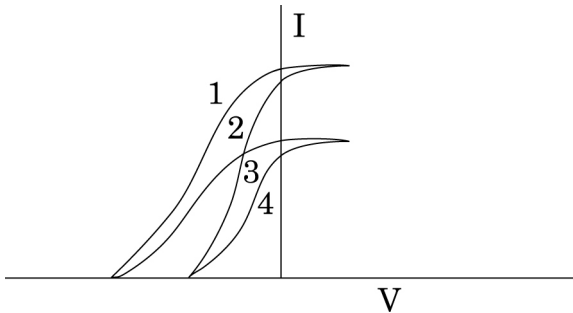

The given graph shows the variation of photo-electric current(I) with the applied voltage(V) for two different materials and for two different intensities of the incident radiations. Identify and explain using Einstein's photo electric equation the pair of curves that correspond to (i) different materials but same intensity of incident radiation, (ii) different intensities but same materials.

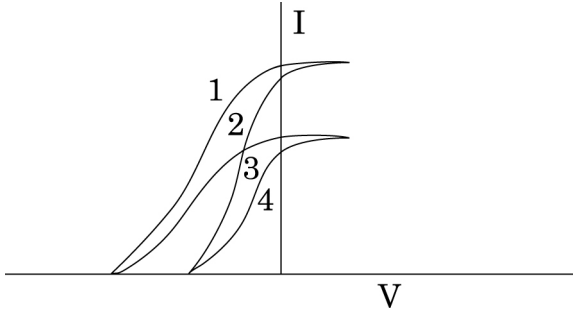

खण्ड - द

SECTION - D

23. शिव के खेतों के ऊपर उच्च वोल्टता टॉवर था। वह अधिकारियों से इसे हटाने के लिए शिकायत करता रहता था, क्योंकि इसने उसके खेत की काफी भूमि घेर रखी थी, उसके चाचा जी, जो शिक्षक हैं, उन्होंने उसे यह समझाया कि शक्ति के दक्ष संचरण के लिए इस प्रकार के टॉवर लगाना क्यों आवश्यक है? जब शिव का संदेह दूर हो गया और उसे इन टॉवरों की उपयोगिता स्पष्ट हो गयी, तो उसने शिकायत करना बन्द कर दिया। 4

उपरोक्त गद्यांश के आधार पर नीचे दिए गए प्रश्नों के उत्तर दीजिए :

- शक्ति का संचरण उच्च वोल्टता पर करना क्यों आवश्यक है?
- “निम्न शक्ति गुणांक उच्च शक्ति-क्षय को उपलक्षित करता है।” व्याख्या कीजिए।
- शिव और उसके चाचा जी द्वारा प्रदर्शित दो मूल्य लिखिए।

Shiv had a high tension tower erected on his farm land. He kept complaining to the authorities to remove it since it occupied a large portion of his land. His uncle, who was a teacher, explained to him the need for erecting these towers for efficient transmission of power. As Shiv got convinced and realized its significance, he stopped complaining.

Based on the above paragraph, answer the following questions :

- Why is it necessary to transport power at high voltages ?
- 'A low power factor implies large power loss'. Explain.
- Write the two values displayed by Shiv and his Uncle.

खण्ड - य
SECTION - E

24. (a) वर्णन कीजिए कि पोलैरोइड के पारित - अक्ष का अभिविन्यास चाहे कुछ भी हो, किसी पोलैरोइड से बाहर आने वाले प्रकाश की तीव्रता में कोई परिवर्तन नहीं होता। 5

(b) उपयुक्त आरेख द्वारा उस शर्त को लिखिए, जिसमें दो पारदर्शी माध्यमों की सीमा रेखा पर आपतित अध्रुवित प्रकाश, ध्रुवित हो जाता है। संक्षेप में वर्णन कीजिए।

इस प्रकार, यह दर्शाए कि आपतन कोण ' i_p ' और अपवर्तनांक μ के बीच संबंध, $\mu = \tan i_p$ होता है।

अथवा

(a) चित्र में दर्शाए अनुसार n_1 और n_2 अपवर्तनांकों के दो माध्यमों को पृथक करने वाले R वक्रता त्रिज्या के किसी गोलीय पृष्ठ द्वारा इसके मुख्य अक्ष पर स्थित किसी बिन्दुकित बिम्ब O का प्रतिबिम्ब 'I' बनता है। यह सिद्ध कीजिए कि :

$$\frac{n_2}{v} - \frac{n_1}{u} = \frac{n_2 - n_1}{R}$$

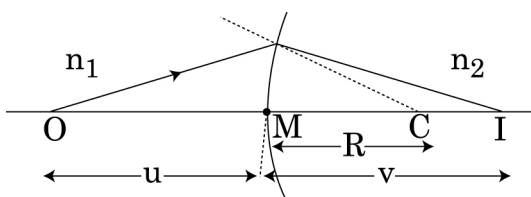

(b) इस व्यंजक का उपयोग करके लेंस मेकर सूत्र व्युत्पन्न कीजिए। आवश्यक किरण आरेख खींचिए।

(c) कोई उत्तल लेंस किसी समतल दर्पण पर स्थित है। अब किसी पिन को इस प्रकार रखा जाता है, कि पिन और लेंस-दर्पण के संयोजन द्वारा बने पिन के प्रतिबिम्ब के बीच कोई लम्बन (पैरेलैक्स) न हो। आप इस प्रेक्षण का उपयोग, उत्तल लेंस की फोकस दूरी ज्ञात करने में, किस प्रकार करेंगे? संक्षेप में व्याख्या कीजिए।

(a) Explain why the intensity of light coming out of a polaroid does not change irrespective of the orientation of the pass axis of the polaroid.

(b) State, using a proper diagram, the condition when unpolarized light incident on the boundary between two transparent media produces polarised light. Explain briefly.

Hence show that the angle of incidence ' i_p ' is related to the refractive index μ by the relation, $\mu = \tan i_p$.

OR

- (a) A point object O on the principle axis of a spherical surface of radius of curvature R separating two media of refractive indices n_1 and n_2 forms an image 'I' as shown in the figure.

Prove that

$$\frac{n_2}{v} - \frac{n_1}{u} = \frac{n_2 - n_1}{R}$$

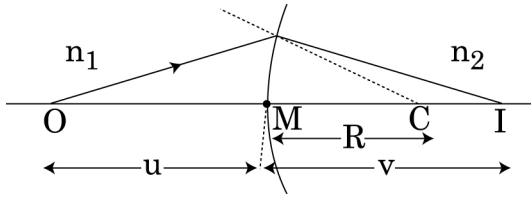

- (b) Use this expression to derive lens maker's formula. Draw the necessary diagram.
- (c) A convex lens is placed over a plane mirror. A pin is now positioned so that there is no parallax between the pin and its image formed by this lens-mirror combination. How will you use this observation to find focal length of the lens? Explain briefly.

25. (i) मीटर ब्रिज की क्रिया विधि का सिद्धान्त लिखिए। मीटर ब्रिज द्वारा किसी अज्ञात प्रतिरोध को ज्ञात करने के लिए परिपथ आरेख खींचिए। उपयोग किया जाने वाला प्रासंगिक सूत्र व्युत्पन्न कीजिए। 5
- (ii) R और S अन्तरालों वाले किसी मीटर ब्रिज में शून्य विक्षेप स्थिति A से 40 cm दूरी पर प्राप्त होती है। यदि प्रतिरोध S के पार्श्व में कोई 30Ω का प्रतिरोध संयोजित कर दिया जाए, तो शून्य विक्षेप स्थिति A से 50 cm दूरी पर प्राप्त होती है। R और S के मान ज्ञात कीजिए।

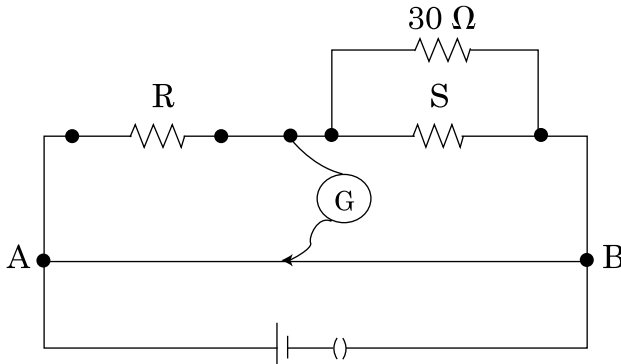

अथवा

- (a) एकसमान विद्युत क्षेत्र \vec{E} में स्थित द्विध्रुव आघूर्ण \vec{p} वाले किसी द्विध्रुव पर कार्यरत बल आघूर्ण के लिए व्यंजक व्युत्पन्न कीजिए। सदिश रूप में लिखते हुए, बल आघूर्ण की दिशा का चित्रण कीजिए। इसे सदिश रूप में अभिव्यक्त कीजिए।
- (b) यह दर्शाइए कि क्षेत्र की दिशा से कोण θ बनाते हुए किसी द्विध्रुव की स्थितिज ऊर्जा संबंध $u(\theta) = -\vec{p} \cdot \vec{E}$ द्वारा व्यक्त की जाती है। इस प्रकार, इसे इसकी अस्थायी संतुलन की स्थिति से स्थायी संतुलन की स्थिति में घूर्णन कराने में किया गया कार्य ज्ञात कीजिए।
- (i) State the principle of working of a meter bridge. Draw the circuit diagram for finding an unknown resistance using a meter bridge. Derive the relevant formula used.
- (ii) In a meter bridge with R and S in the gaps, the null point is found at 40 cm from A. If a resistance of 30Ω is connected in parallel with S, the null point occurs at 50 cm from A. Determine the values of R and S.

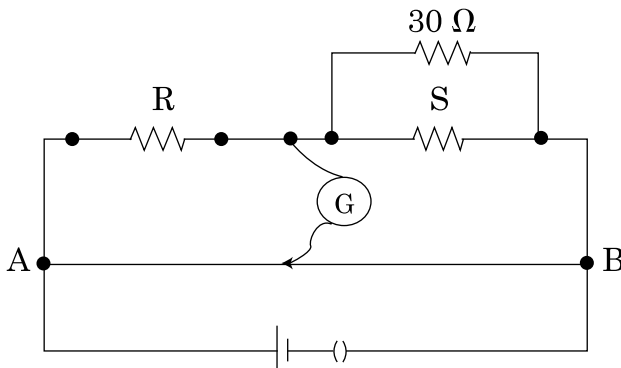

OR

- (a) Deduce the expression for the torque acting on a dipole of dipole moment \vec{p} placed in a uniform electric field \vec{E} . Depict the direction of the torque. Express it in the vector form.
- (b) Show that the potential energy of a dipole making angle θ with the direction of the field is given by $u(\theta) = -\vec{p} \cdot \vec{E}$. Hence find out the amount of work done in rotating it from the position of unstable equilibrium to the stable equilibrium.

26. (i) साइक्लोट्रॉन का नामांकित आरेख खींचिए।
- (ii) यह दर्शाइए कि साइक्लोट्रॉन में आयनों का आवर्तकाल आयन की चाल और वृत्तीय पथ की त्रिज्या पर निर्भर नहीं करता। इस गुण का क्या महत्व है?
- (iii) कोई इलेक्ट्रॉन 100 V विभवान्तर तक त्वरित होने के पश्चात 0.004 T के एकसमान चुम्बकीय क्षेत्र में, जो इसकी गति की दिशा के लम्बवत है, प्रवेश करता है। इलेक्ट्रॉन के वृत्तीय पथ की त्रिज्या परिकलित कीजिए।

अथवा

- (i) दो सीधे, लम्बे, समान्तर चालकों, जिनसे I_1 और I_2 की स्थायी धाराएँ समान दिशा में प्रवाहित हो रही हैं, के कारण चुम्बकीय क्षेत्र रेखाएँ खींचिए।
- (ii) एक चालक के द्वारा दूसरे चालक पर उत्पन्न चुम्बकीय क्षेत्र के लिए व्यंजक लिखिए। प्रति एकांक लम्बाई पर बल के लिए व्यंजक व्युत्पन्न कीजिए।
- (iii) इस बल की दिशा निर्धारित कीजिए।
- (iv) नीचे दर्शाए आरेख में, तार PQ स्थिर है, जबकि वर्गाकार पाश ABCD, इनसे प्रवाहित धाराओं के कारण, गति करने के लिए स्वतंत्र है। कारण सहित यह उल्लेख कीजिए कि पाश किस दिशा में गति अथवा घूर्णन करना आरम्भ करता है।

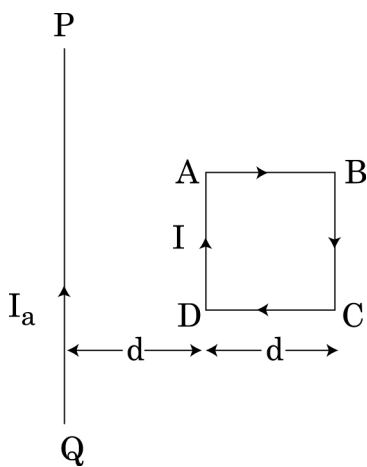

- (i) Draw a neat labeled diagram of a cyclotron.
- (ii) Show that time period of ions in cyclotron is independent of both the speed of ion and radius of circular path. What is the significance of this property?
- (iii) An electron after being accelerated through a potential difference of 100 V enters a uniform magnetic field of 0.004 T perpendicular to its direction of motion. Calculate the radius of the path described by the electron.

OR

- (i) Depict magnetic field lines due to two straight, long, parallel conductors carrying steady currents I_1 and I_2 in the same direction.
- (ii) Write the expression for the magnetic field produced by one of the conductor over the other. Deduce an expression for the force per unit length.
- (iii) Determine the direction of this force.
- (iv) In figure given below, wire PQ is fixed while the square loop ABCD is free to move under the influence of currents flowing in them. State with reason, in which direction does the loop begin to move or rotate ?

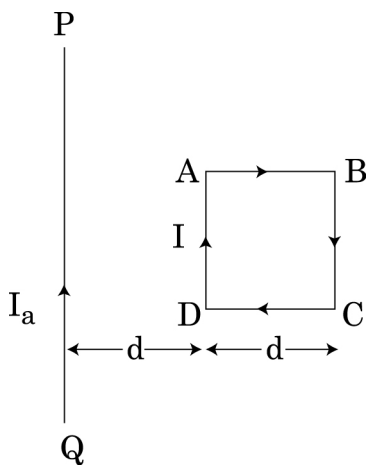

MARKING SCHEME

SET 55/1/E

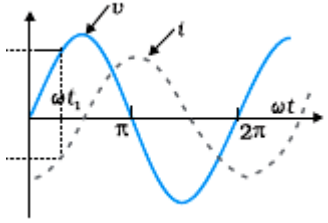
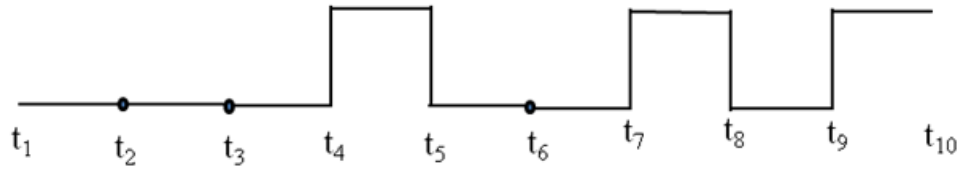
Q. No.	Expected Answer / Value Points	Marks	Total Marks
(SECTION A)			
Set1,Q1 Set2,Q5 Set3,Q2	<p>Potentiometer 'Q' will be preferred</p> <p>Reason:- $Sensitivity \propto \frac{1}{potential\ gradient\ (k)}$</p> <p>Since potential gradient is less, sensitivity is more. [Note: Also accept if the student just writes that potential gradient is less for potentiometer Q]</p>	1/2 1/2	1
Set1,Q2 Set2,Q3 Set3,Q1	 <p>Graph of V Graph of I</p>	1/2 1/2	1
Set1,Q3 Set2,Q2 Set3,Q4	 <p>[Note: If students write truth table correctly then award 1/2 mark.]</p>	1	1
Set1,Q4 Set2,Q4 Set3,Q5	<p>For a.c. source, circuit is complete due to the presence of displacement current in the capacitor. For steady dc, there is no displacement current, therefore, circuit is not complete.</p> <p>[Alternatively, Capacitive reactance $X_c = \frac{1}{2\pi f C} = \frac{1}{\omega C}$</p> <p>So, capacitor allows easy path for a.c. source. For d.c, $f = 0$, so $X_c = \text{infinity}$, So capacitor blocks d.c]</p>	1/2+1/2 1/2+1/2	1
Set1,Q5 Set2,Q1 Set3,Q3	<p>Conductivity of a conductor is the current flowing per unit area per unit electric field applied.</p> <p>[Alternatively, conductivity $\sigma = \frac{J}{E}$]</p>	1/2	

	Depends upon number density i.e. nature of material, and relaxation time i.e. temperature.	1/2	1
(SECTION B)			
Set1,Q6 Set2,Q8 Set3,Q7	<div style="border: 1px solid black; padding: 5px; display: inline-block; margin-bottom: 10px;"> Derivation of expression for work done 2 </div> <p>Work done against the restoring torque</p> $dw = \tau d\theta$ $dw = pE \sin \theta d\theta$ $\therefore, W = pE \int_{\theta_0}^{\theta_1} \sin \theta d\theta$ $= pE \cos \theta_0 - \cos \theta_1$	1/2 1/2 1/2 1/2	2
Set1,Q7 Set2,Q9 Set3,Q6	<div style="border: 1px solid black; padding: 5px; display: inline-block; margin-bottom: 10px;"> de-Broglie wavelength 1/2 Condition of stationary orbits 1/2 Obtaining Bohr's Postulate of quantization of orbital angular momentum. 1 </div> <p>de Broglie wavelength, $\lambda = \frac{h}{mv}$</p> <p>For electron moving in the n^{th} orbit, $2\pi r = n\lambda$</p> $\therefore 2\pi r = \frac{nh}{mv}$ $\therefore mvr = \frac{nh}{2\pi} = L \text{ (orbital angular momentum)}$ <p>This is Bohr's Postulate of quantization of orbital angular momentum.</p>	1/2 1/2 1/2 1/2	2
Set1,Q8 Set2,Q10 Set3,Q9	<div style="border: 1px solid black; padding: 5px; display: inline-block; margin-bottom: 10px;"> Explanation of the concept of Mobile Telephony 1/2 Explanation of working 1/2 </div> <p>Concept of mobile telephony is to divide the service area into a suitable number of cells centred on an office MTSO (Mobile Telephone Switching Office) / Mobile telephony means that you can talk to any person from anywhere.</p> <p><u>Explanation:</u></p> <ol style="list-style-type: none"> 1. Entire service area is divided into smaller parts called cells. 2. Each cell has a base station to receive and send signals to mobiles. 3. Each base station is linked to MTSO. MTSO co-ordinates between 	1/2 1/2 1/2 1/2	2

base station and TCO (Telephone Control Office)											
Set1,Q9 Set2,Q7 Set3,Q10	<table border="1"> <tr> <td>Formula</td> <td>½</td> </tr> <tr> <td>Calculation</td> <td>½</td> </tr> <tr> <td>Longest Wavelength</td> <td>½</td> </tr> <tr> <td>Identification of Series</td> <td>½</td> </tr> </table>	Formula	½	Calculation	½	Longest Wavelength	½	Identification of Series	½		
Formula	½										
Calculation	½										
Longest Wavelength	½										
Identification of Series	½										
	$\frac{1}{\lambda_{max}} = R \left(\frac{1}{n_f^2} - \frac{1}{n_i^2} \right)$	½									
	<p>The energy of the incident photon = 12.5 eV</p> <p>Energy of ground state = -13.6eV</p> <p>∴, Energy after absorption of photon can be -1.1eV</p> <p>This means that electron can go to the excited state $n_i = 3$. It emits photons of maximum wavelength on going to $n_f = 2$ i.e.</p>										
	$\frac{1}{\lambda_{max}} = \left\{ \frac{1}{2^2} - \frac{1}{3^2} \right\} R$	½									
	$\lambda_{max} = \frac{36}{5R}$ $= \frac{36}{5 \times 1.1 \times 10^7}$ $= 6.555 \times 10^{-7} \text{m} = 6555 \text{ \AA}$	½									
	<p>It belongs to Balmer Series.</p> <p>[Note:- (1) If student just writes the formula</p> $\frac{1}{\lambda_{max}} = R \left(\frac{1}{n_f^2} - \frac{1}{n_i^2} \right)$ <p>for the wavelength of different levels in the Hydrogen spectrum and calculates λ_{max} for any series, award full 3 marks. (2) Also award full 3 marks if the student writes that the energy of the excited state cannot be 12.5eV]</p> <p style="text-align: center;">OR</p>	½									
	<table border="1"> <tr> <td>Formula</td> <td>1</td> </tr> <tr> <td>Calculation</td> <td>1</td> </tr> </table>	Formula	1	Calculation	1						
Formula	1										
Calculation	1										



	$v = \frac{nh}{2\pi mr}$ $\text{And } r = \frac{1}{k} \frac{n^2 h^2}{4\pi^2 m e^2}$ $\text{So, } v = k \frac{2\pi e^2}{nh}$ <p>In first excited state n = 2</p> $\text{So velocity } v_2 = \frac{2\pi k e^2}{2h}$ $= 1.09 \times 10^6 \text{ ms}^{-1}$ <p>OR</p> <p>Velocity of electron, $v_n = \frac{1}{137} \frac{c}{n}$</p> <p>In first excited state n = 2</p> <p>So velocity in first excited state (v_2)</p> $= \frac{1}{137} \frac{c}{2}$ $= 1.09 \times 10^6 \text{ ms}^{-1}$	1/2													
		1/2													
		1/2													
		1/2													
		1													
		1/2													
		1/2	2												
Set1,Q10 Set2,Q6 Set3,Q8	<table border="1"> <tbody> <tr> <td>(i)</td> <td>How are infrared waves produced</td> <td>1/2</td> </tr> <tr> <td></td> <td>One important use</td> <td>1/2</td> </tr> <tr> <td>(ii)</td> <td>Reason (any one)</td> <td>1</td> </tr> </tbody> </table> <p>(i) Infrared waves are produced by hot bodies and molecules.</p> <p>Important use(Any one) To treat muscular strains/ To reveal the secret writings on the ancient walls/ For producing dehydrated fruits/ Solar heater/ Solar cooker</p> <p>Ozone layer protects us from harmful U-V rays</p>	(i)	How are infrared waves produced	1/2		One important use	1/2	(ii)	Reason (any one)	1	1/2				
(i)	How are infrared waves produced	1/2													
	One important use	1/2													
(ii)	Reason (any one)	1													
		1/2													
		1	2												
(SECTION C)															
Set1,Q11 Set2,Q15 Set3,Q12	<table border="1"> <tbody> <tr> <td>(i)</td> <td>Electric Flux through the shell</td> <td>1</td> </tr> <tr> <td>(ii)</td> <td>Statement of Law</td> <td>1</td> </tr> <tr> <td>(iii)</td> <td>Force on charge at C</td> <td>1/2</td> </tr> <tr> <td></td> <td>Force on charge at A</td> <td>1/2</td> </tr> </tbody> </table> <p>(i) Electric flux through a Gaussian surface, $\varphi = \frac{\text{total enclosed charge}}{\epsilon_0}$</p>	(i)	Electric Flux through the shell	1	(ii)	Statement of Law	1	(iii)	Force on charge at C	1/2		Force on charge at A	1/2	1/2	
(i)	Electric Flux through the shell	1													
(ii)	Statement of Law	1													
(iii)	Force on charge at C	1/2													
	Force on charge at A	1/2													

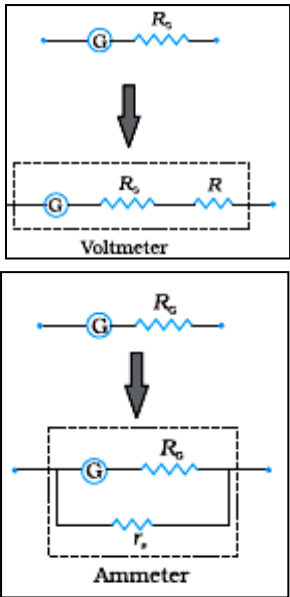

	<p>Net charge enclosed inside the shell $q=0$ \therefore Electric flux through the shell $\frac{q}{\epsilon_0}=0$</p> <p>Award $\frac{1}{2}$ mark even when the student writes - Electric flux through the shell is zero as electric field inside the shell is zero.</p> <p>(ii) Gauss Law- Electric flux through a Gaussian surface is $\frac{1}{\epsilon_0}$ times the net charge enclosed with in it. Alternatively, $\oint \vec{E} \cdot \vec{dS} = \frac{q}{\epsilon_0}$</p> <p>(iii) Force on the charge at the centre i.e. Charge $Q/2 = 0$</p> $F_A = \frac{1}{4\pi\epsilon_0} \frac{2Q \times (Q + Q/2)}{x^2}$ $= \frac{1}{4\pi\epsilon_0} \frac{3Q^2}{x^2}$	<p>$\frac{1}{2}$</p> <p>1</p> <p>$\frac{1}{2}$</p> <p>$\frac{1}{2}$</p>	<p>3</p>
<p>Set1,Q12 Set2,Q13 Set3,Q21</p>	<div style="border: 1px solid black; padding: 5px; margin-bottom: 10px;"> <p>How galvanometer is converted in to a voltmeter and an Ammeter $\frac{1}{2} + \frac{1}{2}$ Diagram for conversion of galvanometer into a voltmeter and an Ammeter. $\frac{1}{2} + \frac{1}{2}$ Resistance of each arrangement $\frac{1}{2} + \frac{1}{2}$</p> </div> <p>A galvanometer is converted into a voltmeter by connecting a high resistance 'R' in series with it.</p> <p>A galvanometer is converted into an ammeter by connecting a small resistance (called shunt) in parallel with it.</p> <div style="text-align: center;">  </div>	<p>$\frac{1}{2}$</p> <p>$\frac{1}{2}$</p> <p>$\frac{1}{2}$</p>	

	Resistance of voltmeter, $R_V = G + R$ Resistance for Ammeter, $R_A = \frac{G r_s}{G + r_s}$	$\frac{1}{2}$ $\frac{1}{2}$	3												
Set1,Q13 Set2,Q14 Set3,Q17	<table border="1"> <tr> <td>(i)</td> <td>Total Internal Reflection (definition)</td> <td>$\frac{1}{2}$</td> </tr> <tr> <td></td> <td>Conditions for T.I.R</td> <td>1</td> </tr> <tr> <td>(ii)</td> <td>Finding the relation between critical angle and Refractive Index</td> <td>1</td> </tr> <tr> <td>(iii)</td> <td>Phenomenon based on Total Internal Reflection</td> <td>$\frac{1}{2}$</td> </tr> </table> <p>(i) When a ray of light travels from a denser medium into a rarer medium at an angle greater than the critical angle, it reflects back into the denser medium. This phenomenon is called total internal reflection. Conditions for total internal reflection</p> <p>(a) Light should travel from denser medium to rarer medium. $\frac{1}{2}$ (b) Angle of incidence should be greater than critical angle. $\frac{1}{2}$</p> <p>(ii) $\frac{1}{\mu} = \frac{\sin i}{\sin r}$, for total internal reflection to occur $i \geq i_c$ at critical angle, angle of refraction $r = 90^\circ$, hence $\frac{1}{\mu} = \frac{\sin i_c}{\sin 90^\circ}$ $\Rightarrow \mu = \frac{1}{\sin i_c}$</p> <p>(iii) Mirage/ sparkling of diamond/ optical fiber/ totally reflecting Prism/ shinning of air bubbles in water.(any one) $\frac{1}{2}$</p>	(i)	Total Internal Reflection (definition)	$\frac{1}{2}$		Conditions for T.I.R	1	(ii)	Finding the relation between critical angle and Refractive Index	1	(iii)	Phenomenon based on Total Internal Reflection	$\frac{1}{2}$	$\frac{1}{2}$ $\frac{1}{2}$ $\frac{1}{2}$ $\frac{1}{2}$	3
(i)	Total Internal Reflection (definition)	$\frac{1}{2}$													
	Conditions for T.I.R	1													
(ii)	Finding the relation between critical angle and Refractive Index	1													
(iii)	Phenomenon based on Total Internal Reflection	$\frac{1}{2}$													
Set1,Q14 Set2,Q21 Set3,Q16	<table border="1"> <tr> <td>Global Positioning System</td> <td>1</td> </tr> <tr> <td>Brief explanation of the Working Principle</td> <td>2</td> </tr> </table> <p>Global Positioning System is method of identifying location or position of any point or a person on earth using a system of 24 satellites, which are continuously orbiting, observing, monitoring and mapping the earth.</p> <p><u>Working Principle:</u></p> <p>(i) The unique location of GPS user is determined by measuring its distance from at least three GPS satellites. $\frac{1}{2}$</p> <p>(ii) Using these values of distances, obtained from three satellites, a microprocessor, fitted in GPS device, determines the exact location. $\frac{1}{2}$</p>	Global Positioning System	1	Brief explanation of the Working Principle	2	1 $\frac{1}{2}$ $\frac{1}{2}$	3								
Global Positioning System	1														
Brief explanation of the Working Principle	2														

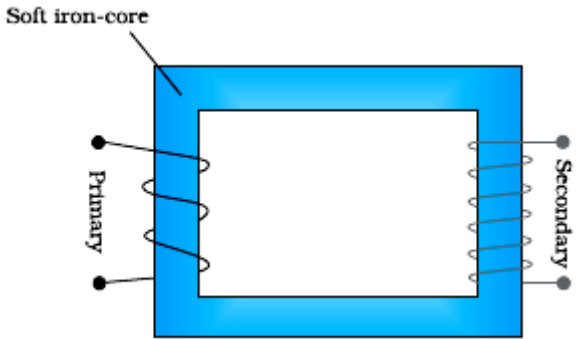
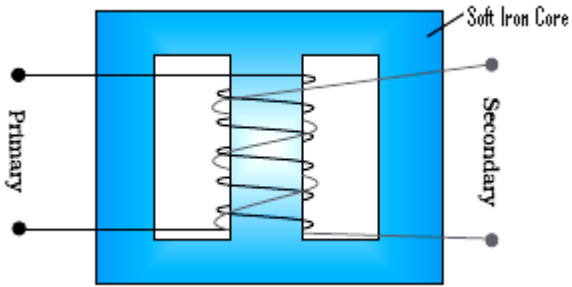

<p>Set1,Q15 Set2,Q18 Set3,Q15</p>	<div style="border: 1px solid black; padding: 5px; margin-bottom: 10px;"> <table style="width: 100%; border-collapse: collapse;"> <tr> <td style="padding: 2px;">Formula for Activity</td> <td style="text-align: right; padding: 2px;">1</td> </tr> <tr> <td style="padding: 2px;">Calculation & result</td> <td style="text-align: right; padding: 2px;">2</td> </tr> </table> </div> <p>Activity, $R = \lambda N$</p> $= \frac{0.693}{T_{1/2}} N$ <p>Activity (R) = $\frac{0.693}{1.42 \times 10^{17}} \times N$</p> <p>Number of nuclei present in 1 gram sample of ${}^{238}_{92}\text{U} = 2503 \times 10^{20}$</p> $\Rightarrow R = \frac{0.693}{1.42 \times 10^{17}} \times \frac{6.0 \times 10^{26}}{238 \times 10^3} \text{ s}^{-1}$ $= 1.23 \times 10^4 \text{ s}^{-1}$	Formula for Activity	1	Calculation & result	2	<p style="text-align: center;">1/2</p> <p style="text-align: center;">1/2</p> <p style="text-align: center;">1/2</p> <p style="text-align: center;">1/2</p> <p style="text-align: center;">1/2</p> <p style="text-align: center;">1/2</p>	<p style="text-align: center;">3</p>				
Formula for Activity	1										
Calculation & result	2										
<p>Set1,Q16 Set2,Q20 Set3,Q19</p>	<div style="border: 1px solid black; padding: 5px; margin-bottom: 10px;"> <table style="width: 100%; border-collapse: collapse;"> <tr> <td style="padding: 2px;">Schematic arrangement</td> <td style="text-align: right; padding: 2px;">1/2</td> </tr> <tr> <td style="padding: 2px;">Principle</td> <td style="text-align: right; padding: 2px;">1/2</td> </tr> <tr> <td style="padding: 2px;">Relation between Primary and Secondary Voltages</td> <td style="text-align: right; padding: 2px;">1</td> </tr> <tr> <td style="padding: 2px;">Relation between currents in Primary and Secondary Coils</td> <td style="text-align: right; padding: 2px;">1</td> </tr> </table> </div> <div style="text-align: center;">  <p>Alternatively,</p>  </div> <p>When the current through the primary coil changes, the magnetic flux through</p>	Schematic arrangement	1/2	Principle	1/2	Relation between Primary and Secondary Voltages	1	Relation between currents in Primary and Secondary Coils	1	<p style="text-align: center;">1/2</p>	
Schematic arrangement	1/2										
Principle	1/2										
Relation between Primary and Secondary Voltages	1										
Relation between currents in Primary and Secondary Coils	1										

	<p>the secondary changes. This produces an induced emf in the secondary coil/ it works on mutual induction.</p> $\varepsilon_s = - N_s \frac{d\varphi}{dt}$ $\varepsilon_p = - N_p \frac{d\varphi}{dt}$ $\frac{\varepsilon_s}{\varepsilon_p} = \frac{N_s}{N_p}$ $i_s \varepsilon_s = i_p \varepsilon_p \text{ (for ideal transformer)}$ $\frac{i_s}{i_p} = \frac{\varepsilon_p}{\varepsilon_s}$	<p>1/2</p> <p>1/2</p> <p>1/2</p> <p>1/2</p> <p>1/2</p>	<p>3</p>								
<p>Set1,Q17 Set2,Q19 Set3,Q11</p>	<div style="border: 1px solid black; padding: 10px; margin-bottom: 20px;"> <table style="width: 100%; border-collapse: collapse;"> <tr> <td style="padding: 5px;">(a) Formula</td> <td style="text-align: right; padding: 5px;">1/2</td> </tr> <tr> <td style="padding: 5px;"> Calculation & result</td> <td style="text-align: right; padding: 5px;">1/2+1/2</td> </tr> <tr> <td style="padding: 5px;">(b) Formula</td> <td style="text-align: right; padding: 5px;">1/2</td> </tr> <tr> <td style="padding: 5px;"> Calculation & result</td> <td style="text-align: right; padding: 5px;">1/2+1/2</td> </tr> </table> </div> <p>(a) $\beta = \frac{\lambda D}{d}$</p> $= \frac{500 \times 10^{-9} \times 1}{10^{-3}}$ $= 0.5 \text{ mm or } 5 \times 10^{-4} \text{ m}$ <p>(b) $\beta_0 = \frac{2\lambda D}{a} = 10 \beta$</p> $a = \frac{2 \times 500 \times 10^{-9} \times 1}{10 \times 5 \times 10^{-4}}$ $a = 2 \times 10^{-4} \text{ m or } 0.2 \text{ mm}$	(a) Formula	1/2	Calculation & result	1/2+1/2	(b) Formula	1/2	Calculation & result	1/2+1/2	<p>1/2</p> <p>1/2</p> <p>1/2</p> <p>1/2</p> <p>1/2</p> <p>1/2</p>	<p>3</p>
(a) Formula	1/2										
Calculation & result	1/2+1/2										
(b) Formula	1/2										
Calculation & result	1/2+1/2										

Set1,Q18
Set2,Q11
Set3,Q13

Circuit Diagram	1
Transistor action (brief explanation)	1
Shape of Input and output characteristics	1/2+1/2

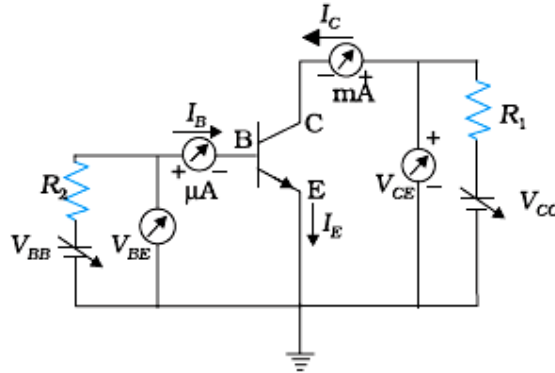

Transistor works only when its emitter base junction is forward biased and collector emitter junction is reversed biased. Due to this the majority charge carriers from the emitter, accelerate to collector side and create I_e, I_b and I_c such that $I_e = I_b + I_c$

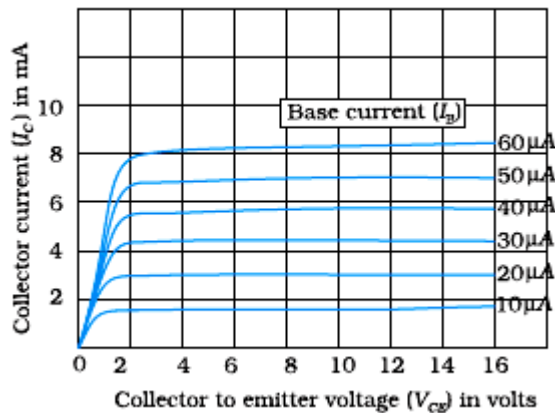
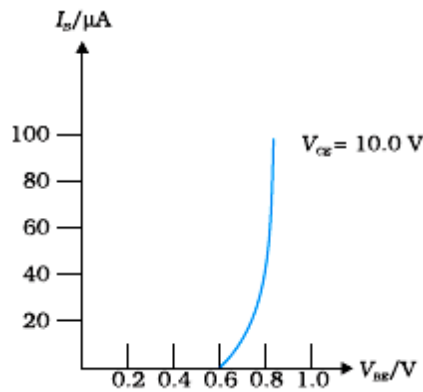

1

1

1/2

1/2

3

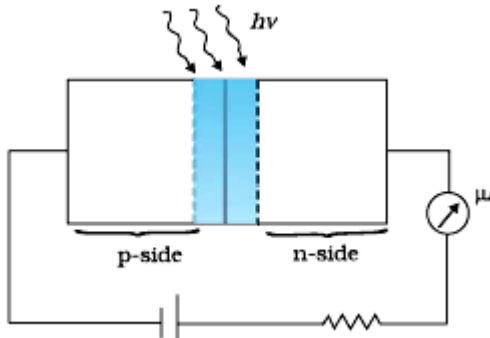
<p>Set1,Q19 Set2,Q22 Set3,Q20</p>	<table border="1" style="width: 100%;"> <tr> <td>Identification of materials having same Intensity of incident radiation</td> <td style="text-align: right;">$\frac{1}{2} + \frac{1}{2}$</td> </tr> <tr> <td>Explanation</td> <td style="text-align: right;">$\frac{1}{2}$</td> </tr> <tr> <td>Identification of materials that correspond to different intensities.</td> <td style="text-align: right;">$\frac{1}{2} + \frac{1}{2}$</td> </tr> <tr> <td>Explanation</td> <td style="text-align: right;">$\frac{1}{2}$</td> </tr> </table> <p>(1, 2) correspond to same intensity but different material. $\frac{1}{2}$</p> <p>(3, 4) correspond to same intensity but different material. $\frac{1}{2}$</p> <p>As saturation currents are same and stopping potentials are different. $\frac{1}{2}$</p> <p>(1, 3) correspond to different intensity but same material. $\frac{1}{2}$</p> <p>(2, 4) correspond to different intensity but same material. $\frac{1}{2}$</p> <p>As stopping potentials are same but saturation currents are different. $\frac{1}{2}$</p>	Identification of materials having same Intensity of incident radiation	$\frac{1}{2} + \frac{1}{2}$	Explanation	$\frac{1}{2}$	Identification of materials that correspond to different intensities.	$\frac{1}{2} + \frac{1}{2}$	Explanation	$\frac{1}{2}$		3
Identification of materials having same Intensity of incident radiation	$\frac{1}{2} + \frac{1}{2}$										
Explanation	$\frac{1}{2}$										
Identification of materials that correspond to different intensities.	$\frac{1}{2} + \frac{1}{2}$										
Explanation	$\frac{1}{2}$										
<p>Set1,Q20 Set2,Q17 Set3,Q22</p>	<table border="1" style="width: 100%;"> <tr> <td>(i) Working with circuit diagram</td> <td style="text-align: right;">1+1</td> </tr> <tr> <td>(ii) Characteristics of a photodiode for different illumination intensities</td> <td style="text-align: right;">$\frac{1}{2}$</td> </tr> <tr> <td>(iii) Reason for operating photodiode in reverse bias</td> <td style="text-align: right;">$\frac{1}{2}$</td> </tr> </table> <p>(i)</p> <div style="text-align: center;">  </div> <p>(a) When light with energy $h\nu > (\text{energy gap}) E_g$ falls on photodiode, electron-hole pairs are generated. $\frac{1}{2}$</p> <p>(b) Due to electric field at the junction, electrons and holes are separated before they combine. $\frac{1}{2}$</p> <p>(c) Electrons are collected on n-side and holes are collected on p-side giving rise to an emf and current flows in external load. $\frac{1}{2}$</p>	(i) Working with circuit diagram	1+1	(ii) Characteristics of a photodiode for different illumination intensities	$\frac{1}{2}$	(iii) Reason for operating photodiode in reverse bias	$\frac{1}{2}$				
(i) Working with circuit diagram	1+1										
(ii) Characteristics of a photodiode for different illumination intensities	$\frac{1}{2}$										
(iii) Reason for operating photodiode in reverse bias	$\frac{1}{2}$										

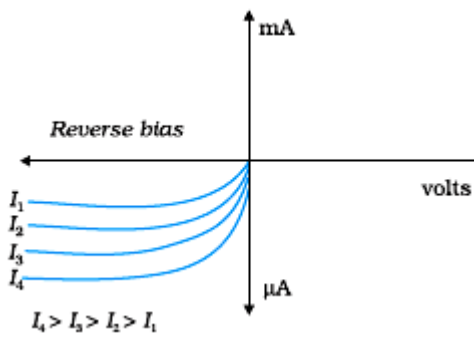
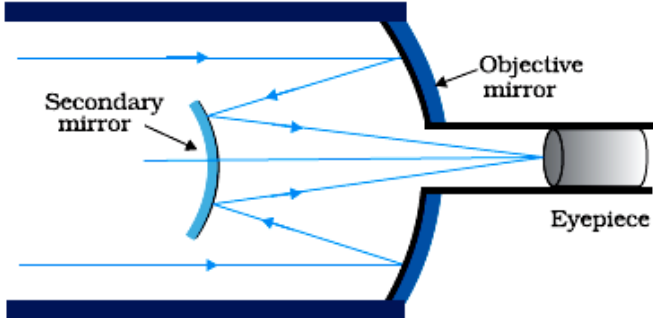
	<p>(ii)</p>  <p>(iii) It is easier to observe the change in the current, with change in the light intensity, when reverse bias is applied.</p>	1/2											
<p>Set1,Q21 Set2,Q16 Set3,Q14</p>	<table border="1" data-bbox="305 688 1302 787"> <tr> <td>(a) Ray diagram of reflecting telescope</td> <td>2</td> </tr> <tr> <td>(b) Advantages of reflecting type telescope over refracting telescope</td> <td>1</td> </tr> </table>  <p>(a)</p> <p>(b) <u>Advantages (any two)</u></p> <ul style="list-style-type: none"> (i) There is no chromatic aberration in a mirror. (ii) Brighter image (iii) High resolving Power (iv) Large light gathering power (v) Large magnifying power <p style="text-align: center;">OR</p> <table border="1" data-bbox="313 1564 1299 1696"> <tr> <td>(i) Ray diagram of a compound microscope</td> <td>1 1/2</td> </tr> <tr> <td>(ii) Expression for resolving power of compound microscope.</td> <td>1</td> </tr> <tr> <td>How can resolving power of microscope be increased.</td> <td>1/2</td> </tr> </table>	(a) Ray diagram of reflecting telescope	2	(b) Advantages of reflecting type telescope over refracting telescope	1	(i) Ray diagram of a compound microscope	1 1/2	(ii) Expression for resolving power of compound microscope.	1	How can resolving power of microscope be increased.	1/2	<p>2</p> <p>1/2+1/2</p>	<p>3</p>
(a) Ray diagram of reflecting telescope	2												
(b) Advantages of reflecting type telescope over refracting telescope	1												
(i) Ray diagram of a compound microscope	1 1/2												
(ii) Expression for resolving power of compound microscope.	1												
How can resolving power of microscope be increased.	1/2												

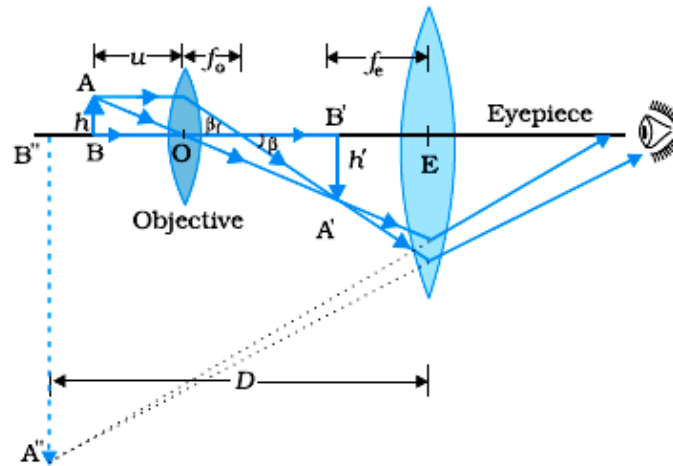

(i)

$$\text{Resolving power of compound microscope} = \frac{2\mu \sin \theta}{1.22\lambda}$$

Resolving power can be increased by decreasing wavelength and by increasing refracting index of medium.

1½

1

½

3

Set1,Q22
Set2,Q12
Set3,Q18

Equivalent capacitance between Point A and B	2
Charge drawn from battery	1

$$\therefore \frac{C_1}{C_2} = \frac{C_3}{C_4}$$

This is the condition of balance so there will be no current across PR (50 μ F capacitor)

Now C_1 and C_2 are in series

$$C_{12} = \frac{C_1 C_2}{C_1 + C_2} = \frac{10 \times 20}{10 + 20} = \frac{200}{30} = \frac{20}{3} \mu\text{F}$$

$\therefore C_3$ and C_4 are in series

$$C_{34} = \frac{C_3 C_4}{C_3 + C_4} = \frac{5 \times 10}{5 + 10} = \frac{50}{15} = \frac{10}{3} \mu\text{F}$$

Equivalent capacitance between A and B is

$$C_{AB} = C_{12} + C_{34} = \frac{20}{3} + \frac{10}{3} = 10 \mu\text{F}$$

½

½

½

½

	Charge drawn from battery (q) = CV = 10 x 10 μC = 100 μC or 10 ⁻⁴ C	1/2 1/2	3								
<u>(SECTION D)</u>											
Set1,Q23 Set2,Q23 Set3,Q23	<table border="1" style="width: 100%;"> <tr> <td>(a.) Reason of transportation of Power at high voltages</td> <td style="text-align: right;">1</td> </tr> <tr> <td>(b.) Explanation</td> <td style="text-align: right;">1</td> </tr> <tr> <td>(c.) Two values displayed by (i) Shiv</td> <td style="text-align: right;">1/2 + 1/2</td> </tr> <tr> <td style="padding-left: 40px;">(ii) Uncle</td> <td style="text-align: right;">1/2 + 1/2</td> </tr> </table> <p>(a) To reduce power losses in the transmission line.</p> <p>(b) Since power loss is inversely proportional to power factor</p> <p>(P = VI cos φ where cos φ is power factor). To supply a given power at a given voltage, if cos φ is small, we have to increase current accordingly. This will lead to large power loss (I²R) in transmission /</p> $(Effective\ Power = \frac{True\ Power}{\cos\ \phi})$ <p>(c) Values displayed by</p> <p>(i) Shiv – understanding nature/ respecting elders/ helping nature/ caring/ etc.</p> <p>(ii) Uncle– knowledgeable/ helping nature/ caring/ etc.(Any two each)</p>	(a.) Reason of transportation of Power at high voltages	1	(b.) Explanation	1	(c.) Two values displayed by (i) Shiv	1/2 + 1/2	(ii) Uncle	1/2 + 1/2	1 1 1/2+1/2 1/2+1/2	4
(a.) Reason of transportation of Power at high voltages	1										
(b.) Explanation	1										
(c.) Two values displayed by (i) Shiv	1/2 + 1/2										
(ii) Uncle	1/2 + 1/2										
<u>(SECTION E)</u>											

Set1,Q24
Set2,Q26
Set3,Q25

(i)	Labelled diagram of cyclotron	1
(ii)	Showing the independence of time period on speed and radius Significance of the property	1½ ½
(iii)	Calculation of radius of path	2

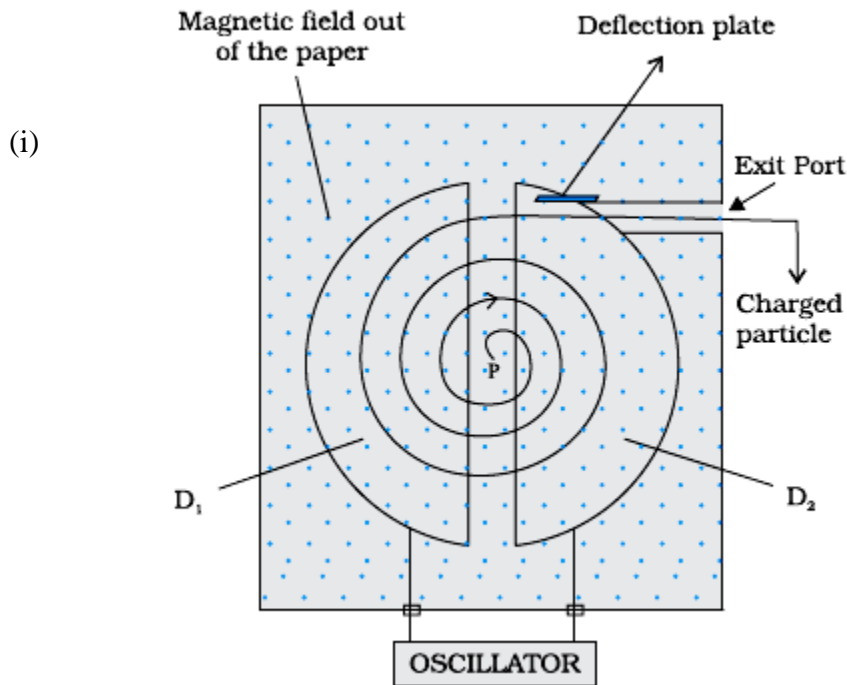

[Note: Deduct ½ mark of this diagram, if the student does not show the labeling.]

$$\therefore \frac{mv^2}{r} = qvB$$

$$r = \frac{mv}{qB}$$

$$T = \frac{2\pi r}{v} = \frac{2\pi m}{qB}$$

This shows that time period is independent of speed and radius of circular path.

Significance: Due to this, the charged particle remains in phase with frequency of the applied voltage in cyclotron

Alternatively,

1

½

½

½

½

Significance: The applied voltage is adjusted so that the polarity of dees is reversed in the same time that it takes the ion to complete one half of the revolution.

[Alternatively,
It helps in achieving resonance conduction.]

$$(ii) \quad r = \frac{mv}{qB} = \frac{\sqrt{2mqV}}{qB}$$

$$r = \frac{\sqrt{2 \times 9.1 \times 10^{-31} \times 1.6 \times 10^{-19} \times 100}}{1.6 \times 10^{-19} \times 0.004} \text{ m}$$

$$r = \frac{5.4 \times 10^{-24}}{6.4 \times 10^{-22}} \text{ m}$$

$$r = 8.4 \times 10^{-3} \text{ m}$$

1/2

1/2

1/2

1/2

5

OR

- | | | |
|-------|---|-------|
| (i) | Magnetic field lines due to straight, long, parallel conductors | 1 |
| (ii) | Expression for magnetic field produced | 1/2 |
| | Expression for force per unit length | 1 |
| (iii) | Direction of this force | 1/2 |
| (iv) | Direction of movement/ rotation of loop | 1/2 |
| | Reason for the same | 1 1/2 |

(i)

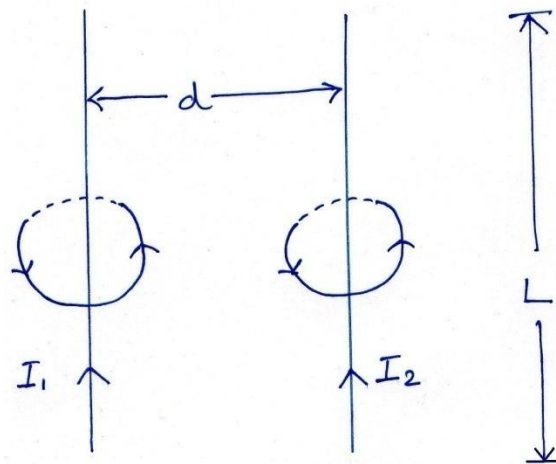

1/2 + 1/2

$$(ii) \quad B_1 = \frac{\mu_0 I_1}{2\pi d} \text{ or } \frac{\mu_0 I_2}{2\pi d} = B_2$$

1/2

$$F = F_{12} = F_{21} = I_1 B_2 L = I_2 B_1 L$$

1/2

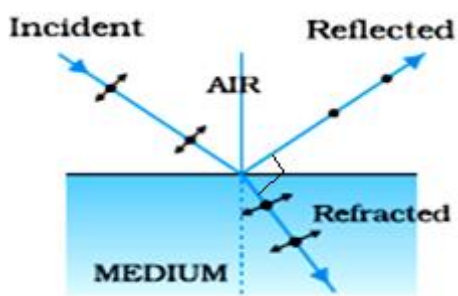
	$= \left(\frac{\mu_0 I_1 I_2}{2\pi d} \right) L$ <p>Force per unit length $\frac{F}{L} = \frac{\mu_0 I_1 I_2}{2\pi d}$</p> <p>(iii) Attractive force (iv) Loop ABCD will move towards wire PQ.</p> <p>Current in wire PQ and Current in arm AD are in the same direction, so they attract each other.</p> <p>Current in wire PQ and Current in arm BC are in opposite direction, so they repel each other.</p> <p>Contribution due to current in AB and CD nullify each other.</p> <p>Since arm AD is nearer than arm BC to arm PQ, so net force on the loop is attractive. Therefore, the loop will move towards the wire PQ.</p>	<p>1/2</p> <p>1/2</p> <p>1/2</p> <p>1/2</p> <p>1/2</p> <p>1/2</p>	<p>5</p>								
<p>Set1,Q25 Set2,Q24 Set3,Q26</p>	<table border="1" style="margin-left: auto; margin-right: auto;"> <tbody> <tr> <td>(a) Explanation</td> <td>2</td> </tr> <tr> <td>(b) Diagram</td> <td>1</td> </tr> <tr> <td>Explanation</td> <td>1/2</td> </tr> <tr> <td>Proof of relation $\mu = \tan i_p$</td> <td>1</td> </tr> </tbody> </table> <p>(a) When unpolarized light passes through a polariser, vibrations perpendicular to the axis of the polaroid are blocked.</p> <p>Unpolarised light have vibrations in all directions.</p> <p>Hence, if the Polariser is rotated, the unblocked vibrations remain same with reference to the axis of Polariser</p> <p>Hence for all positions of Polaroid, half of the incident light always get transmitted. Hence, the intensity of the light does not change.</p> <p>(b)</p> <div style="text-align: center;">  </div>	(a) Explanation	2	(b) Diagram	1	Explanation	1/2	Proof of relation $\mu = \tan i_p$	1	<p>1/2</p> <p>1/2</p> <p>1/2</p> <p>1/2</p> <p>1</p>	
(a) Explanation	2										
(b) Diagram	1										
Explanation	1/2										
Proof of relation $\mu = \tan i_p$	1										

When angle of incidence(i) is equal to the polarising angle(i_β), the reflected light is totally plane polarised.
 [Alternatively: When the refracted ray is perpendicular to the reflected ray, the reflected light is totally plane polarised.]

From $\mu = \frac{\sin i}{\sin r}$

For $i=i_\beta, r = 90-i_\beta$

So, $\mu = \frac{\sin i_\beta}{\sin (90-i_\beta)}$

$= \frac{\sin i_\beta}{\cos i_\beta}$

$\mu = \tan i_\beta$

OR

(a) Derivation	2
(b) Lens makers formula – derivation	1½
Diagram	½
(c) Focal length of the lens	½
Explanation	½

(a)

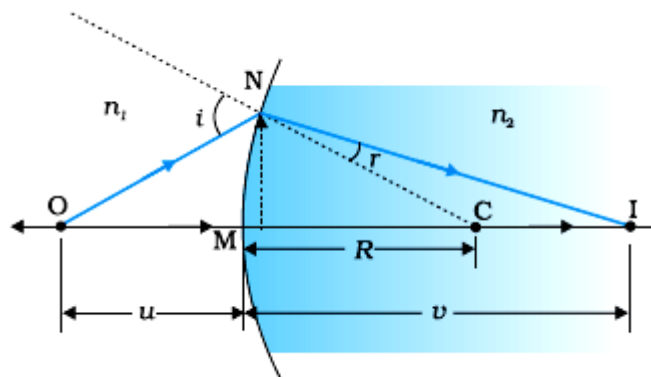

$i = \frac{MN}{OM} + \frac{MN}{MC}$

$r = \frac{MN}{MC} - \frac{MN}{MI}$

½

½

½

½

5

½

½

½

$$n_1 i = n_2 r$$

$$\frac{n_1}{OM} + \frac{n_2}{MI} = \frac{n_2 - n_1}{MC}$$

$$OM = -u, MI = +v, MC = +R$$

$$\frac{n_2}{v} - \frac{n_1}{u} = \frac{n_2 - n_1}{R}$$

1/2

(b) Applying above relation to refraction of light through a convex lens ABCD

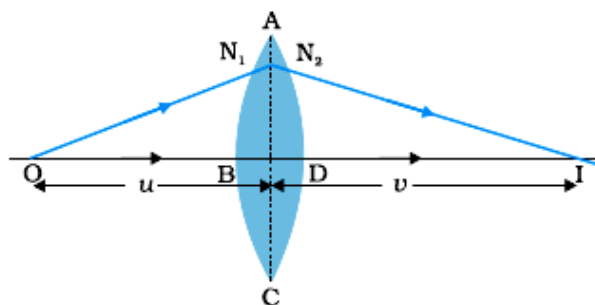

1/2

For interface ABC $\frac{n_2}{v_1} - \frac{n_1}{u} = \frac{n_2 - n_1}{R_1}$

1/2

For interface ADC $\frac{n_1}{v} - \frac{n_1}{v_1} = \frac{n_1 - n_2}{R_2}$

1/2

$$\therefore \frac{n_1}{v} - \frac{n_1}{u} = (n_2 - n_1) \left(\frac{1}{R_1} - \frac{1}{R_2} \right)$$

1/2

$$\text{or } \frac{1}{f} = (n_{21} - 1) \left(\frac{1}{R_1} - \frac{1}{R_2} \right)$$

1/2

(c) Focal length = distance of the pin from the mirror.

The rays from the object after refraction from lens should fall normally on the Plane mirror. So they retrace their path. Hence, rays must be originating from focus and thus distance of the pin from the plane mirror gives focal length of the lens.

1/2

5

Set1,Q26
Set2,Q25
Set3,Q24

(i)	Principle	1
	Circuit diagram	1
	Derivation	1
(ii)	Determination of value of R	1
	Determination of value of S	1

(i)

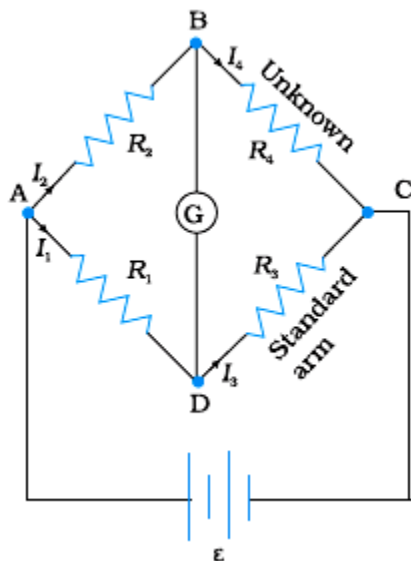

Let four resistors R_1 , R_2 , R_3 and R_4 be connected to form a quadrilateral ABCD with a battery connected across A & C and a galvanometer between B & D. If galvanometer shows no deflection, then

$$\frac{R_2}{R_1} = \frac{R_4}{R_3}$$

(ii)

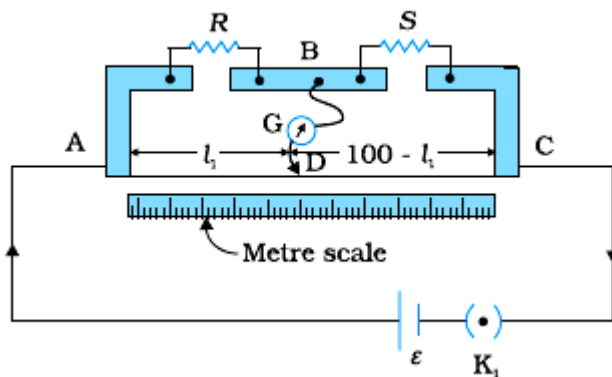

If galvanometer shows no deflection

1

1

$$\frac{l_1}{(100 - l_1)} = \frac{R}{S}$$

$$R = S \frac{l_1}{(100 - l_1)}$$

(iii)

As bridge is balanced

$$\frac{R}{S} = \frac{40}{60} = \frac{2}{3}$$

$$\text{Also, } \frac{R}{\left(\frac{30S}{30+S}\right)} = \frac{50}{50} = 1$$

Solving, $R = 10 \Omega$

$S = 15 \Omega$

OR

(a) Expression for torque (derivation)	1½
Direction of torque	½
Expression in vector form	½
(b) Proof $U(\theta) = -\vec{p} \cdot \vec{E}$	1½
(c) Work done	1

(a)

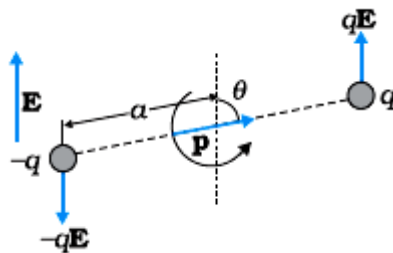

Magnitude of torque = magnitude of either force multiplied by the arm of the couple.

$$= qE \times 2a \sin \theta$$

$$= pE \sin \theta$$

Direction of torque is perpendicular to the plane containing \vec{p} and \vec{E} .

½

½

½

½

½

½

5

½

½

½

½

	<p>Vector form $\vec{\tau} = \vec{p} \times \vec{E}$</p> <p>(b) Work done by external torque in rotating a dipole in uniform electric field is stored as the Potential energy of the system. $U(\theta_0 \rightarrow \theta) = W(\theta_0 \rightarrow \theta) = pE(\cos \theta_0 - \cos \theta_1)$</p> <p>For $\theta_0 = \frac{\pi}{2}$ and $\theta_1 = \theta$ $U(\theta) = pE \left(\cos \frac{\pi}{2} - \cos \theta \right) = -pE \cos \theta = -\vec{p} \cdot \vec{E}$</p> <p>For rotating dipole from position of unstable equilibrium ($\theta_0 = 180^\circ$) to the stable equilibrium ($\theta = 0^\circ$)</p> <p>$\therefore W_{req} = pE(\cos 180^\circ - \cos 0^\circ)$ $= pE(-1 - 1) = -2pE$</p>	<p>1/2</p> <p>1/2</p> <p>1/2</p> <p>1/2</p> <p>1/2</p> <p>1/2</p>	<p>5</p>
--	---	---	----------